

barduva 

- > FLEXIBLE DESIGN
- > LOW SPACE REQUIREMENTS
- > HIGH LEVEL OF SECURITY
- > POWER-SAVING TECHNOLOGIES
- > SMART DIGITAL CONTROL SYSTEM
- > SMOOTH ADJUSTABLE MOVEMENT
- > FAST AND INTUITIVE INSTALLATION
- > EXTERIOR DESIGN OPTIONS
- > DURABLE SCREW DRIVE
- > WIDE RANGE OF OPTIONS AND ACCESSORIES

SB 200

HOME LIFT



MADE IN EU



barduva 

SB 200

Home Lift

SB200 is a screw driven vertical platform lift assembled using high quality materials and designed to meet the characteristics of ultimate performance and outstanding aesthetics. It is designed to use in private houses, cottages and apartment buildings.

SB200 can be installed into existing shaft or its own shaft which is constructed of special multilayered steel sandwich type panels or glass panels.

A maximum of three doors may be installed on each floor with either left or right swing. The doors on the top floor stop may be designed in the form of gates. This type of construction

looks aesthetic and modern and gives a clear view of the surroundings.

An uniformly backlit control panel, with a comfortable handle below, contains large buttons with embossed symbols at a convenient height for accessing from sitting or standing positions. In case of a power outage, the operation of lift continue to work from a backup voltage source.

You can make your own lift solution by choosing from wide variety of accessories and options, such as different lighting, door openers, comfort equipment.

**SB200 PLATFORM LIFT WILL ADVANCE YOUR HOME
AND MAKE EVERY DAY LIFE ENJOYABLE!**



DIFFERENT DOOR TYPES

Gates; Aluminum with glass; With Impost; Aluminum; Fire proof EI60; Fire proof EW60 – with a small window.

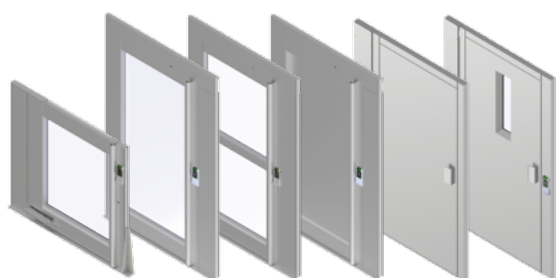

AUTOMATIC DOOR OPENERS

Internal or external door openers opens and closes the door automatically after a preset time. Can be ordered as option.

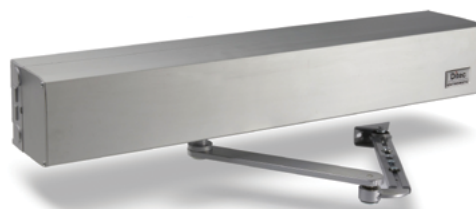

PANELS

Platform lift shaft can be assembled using multi-layered sandwich panels and laminated glass panels.

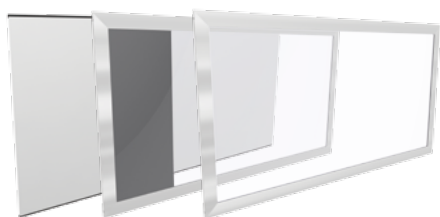

FLOORING

Lift platform floor can be covered with different colour rubber or desired texture vinyl.



OPTIONS

- Automatic door openers
- Additional floor indicators
- Automatic emergency lowering
- LED lighting
- Extra lighting options
- Voice announcer and musical theme
- Floor indicator on the platform or landing
- Ramp
- Phone on the platform
- Safeline
- Electronic contact and non-contact keys
- Remote control

COLOUR CUSTOMISATION

The whole lift can be painted in almost any colour to suit your taste and environment. You can choose from hundreds of RAL palette colours available.



SPECIFICATIONS

Environment	Indoors and outdoors
Drive system	Screw-driven
Rated load	Up to 400 kg / 5 persons
Speed	0.15 m/sec (9 m/min)
Travel height	Up to 13 metres
Landings	Up to 6
Platform dimensions (X x Y, mm)	1100 x 1400 1070 x 1485 *available custom dimensions 1150 x 1485
Shaft dimensions (M x N, mm)	1500 x 1460 1460 x 1540 1540 x 1540
Door clearance (width x height, mm)	900 x 2000 (with 1100 x 1400 platform) 940 x 2000 *available other dimensions
Gate (width x height, mm)	900 x 1300 (with 1100 x 1400 platform) 940 x 1300
Door configuration	Right or left swing, up to 3 doors per landing
Shaft walls	Aluminium profiles with glass or steel panels
Standard colors	RAL 9006 (light grey aluminum) RAL 9010 (pure white) *any RAL color available as option
Soft start/stop	Comes as a standard
Power supply	220-230 V, 1 phase, 40A; 380-400 V, 3 phase, 25A, 50 or 60 Hz
Motor	2.2 kW
Noise level	Less than 70 dB
Control system	Micro computer based
Technical safety equipment	Safety edge around the platform, emergency STOP buttons, electronic speed control, overload detector, opening control of doors and locks, electronic control of engine performance

Complies with the European platform lifts standard EN81-41:2010

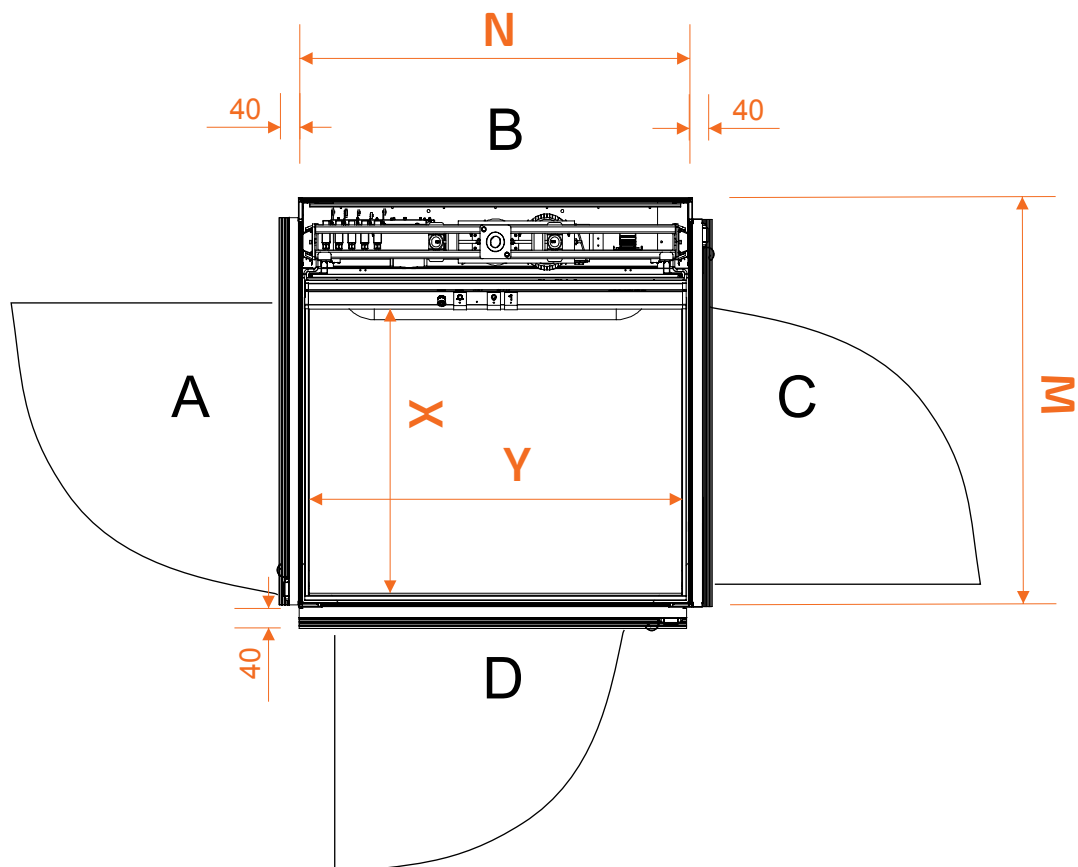



WE ARE CONSTANTLY THINKING ABOUT TOMORROW, BECAUSE WE KNOW THAT THE SUCCESS BELONGS TO THOSE WHO BEST PREDICTS THE NEEDS OF CUSTOMERS. WE LOVE CHALLENGES. WE ARE READY TO FULFILL CUSTOMER ORDERS FASTER THAN OTHERS AND FULFILL ORDERS THAT OTHER COMPANIES DO NOT DARE TO TAKE.



Barduva, JSC

Liepkalnio 61, 02120 Vilnius, Lithuania

00 370 5 231 0770 (Phone)

00 370 5 231 0773 (Fax)

sales@barduva.eu

www.barduva.eu · www.platformlifts.eu